

## 8" Rotary Positioning Tables

Our 8" rotary tables are designed with high quality and affordability in mind



### Key Features

- Precision manufacturing in USA
- High accuracy and repeatability
- Lightweight, cost effective, aluminum construction
- 8" outside diameter for high rigidity
- The use of one single thin section, large diameter, preloaded roller bearing creates:
  - Significant increase in rigidity, stability and stiffness
  - Super low profile -- a striking 0.713" (VR-3153 model) -- considering the 8" diameter
  - Reduced weight, inertia and cost
- Large open frame - 5.50" aperture
- Large penetrating angle - 172° (VR-3153 model)
- Worm gear drive
- Two preloaded ball bearings eliminates play on the worm shaft
- NEMA 17 flange
- Automatic and manual operation
- Motors and single axis intelligent servo controllers are available options

## Specifications

Basic Model		VR-3152	VR-3153 (Slim)
Total Travel		360° Continuous	
Ratio		90 : 1	
Worm	Material	303 Stainless Steel	
	Pitch	48	
	Thread	Quadruple	
	Bearing	Preloaded Ball Bearings Assembly	
Worm Wheel	Material	Bronze QQ-13-637, Alloy 464	
	Pitch	48	
	Thread	Quadruple	
	Bearing	Preloaded Cross Roller, Low Section	
Profile	Thickness	1.575"	0.713"
	Outside Dia	8.000"	
Clear Aperture Diameter		5.500"	
Resolution		.003°	
Accuracy		.02°	
Repeatability		.002°	
Roller Bearing Load Capability	Axial	200 lbs.	
	Radial	100 lbs.	
Maximum Speed		240°/sec.	
Body Material		Aluminum 6061	
Finish		Black Anodize	
Penetrating Angle Range		From 16° to 164°	From 8° to 172°

## Dimensions

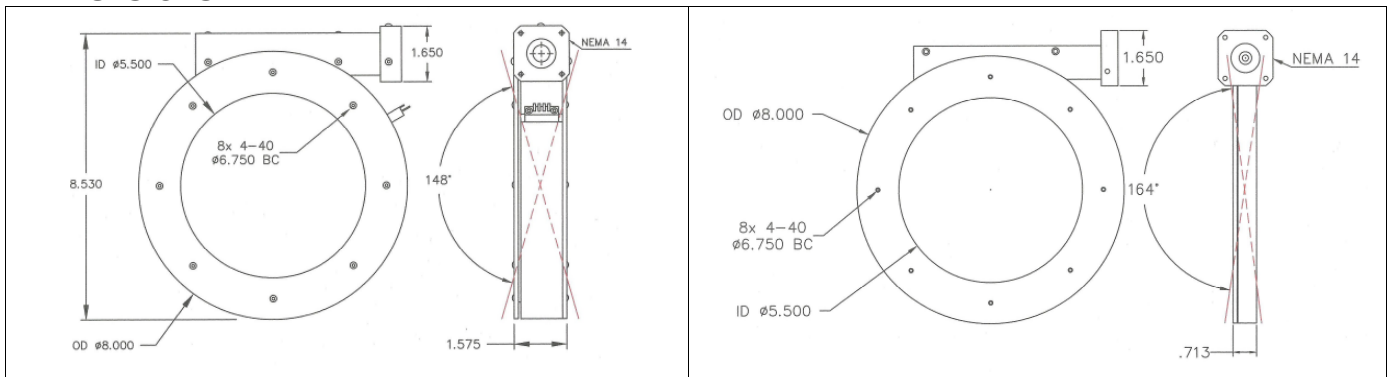

**VR-3152**

**VR-3153**



VIDEO ROBOTICS, INC.  
 1349 W. 166<sup>th</sup> Street  
 Gardena, CA 90247 U.S.A.  
 Telephone: 1-310-324-0055  
 Website: [www.videorobotics.com](http://www.videorobotics.com)